

## GS PRO 25S4 1150X525

Professional hand pallet truck (2.500 kg)



### LIFTER GS PRO

The GS PRO Series is an excellent tool for lifting and carrying loads on pallets or size-standardised containers, thanks to its lightweight, smooth movement and manoeuvrability.



### HYDRAULIC UNIT

Resistant and reliable one piece cast iron pump, worked with numerical control machine, including:

- **MAXIMUM PRESSURE VALVE:** safety device that ensures the transpallet against overloads. When the pressure inside the hydraulic circuit exceeds the set calibration value according to the maximum nominal flow, the valve automatically locks the forks.
- **PROPORTIONAL LOWERING VALVE:** lowering speed can be proportionally controlled according to the lever position on the tiller. Perfect working tool to carry fragile and delicate loads like crystal, glass and ceramics.



### LAKIEROWANIE

Podstawa jest malowana odpornym na obciążenia dynamiczne lakierem epoksydowym w temp. 250°C. Daje to wysoką jakość końcową i decyduje o wspaniałej odporności podczas codziennego użytkowania i zabezpiecza przed wpływem warunków atmosferycznych.

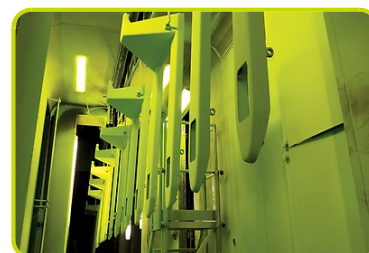

## STANDARD CONFIGURATION

- Nylon - Poly 55 steering wheels
- Nylon rollers
- 4 Curves handle with all the controls (lowering / drive position / lifting) available in a single lever for simple and safe control



- Entry/exit rollers. Supplementary rollers to allow easier entrance and quicker exit from a closed pallet, reducing the impact on the main rollers and guaranteeing a longer life.



## OPTIONAL CONFIGURATION

- Nylon steering wheels
- Aluminium - Poly steering wheels
- Aluminium - Rubber steering wheels



- Polyurethane rollers



- 4 Curves ergonomic handle. The soft rubber covering aids operator comfort and helps to reduce vibration, enabling a more comfortable and secure grip.



- Manual control brake. The brake of the pallet truck, available with rubber steering wheels, is adjustable through the tiller lever to ensure safe use on slopes and ramps. The locking function makes it possible to park the pallet truck even on slopes without rolling away.



- Quick lift. The perfect tool to lift quicker your loads up to 150 kg. The hydraulic pump is specifically engineered to cut job time and increase efficiency. It takes just 6 strokes to raise a pallet to full height, instead of 13 with the traditional HPT.



## Opis

1.1 Producent			LIFTER
1.3 Napęd			Ręczne
1.4 Typ operatora			Pieszny
1.5 Ładowność	Q	Kg	2500
1.6 Odległość środka ciężkości	c	mm	600
1.8 Nacisk na oś do końca wideł	x	mm	932
1.9 Rozstaw osi	y	mm	1192

## Waga

2.1 Waga serwisowa		Kg	63
2.2 Nacisk na tylną oś z ładunkiem		Kg	1796
2.2 Nacisk na przednią oś z ładunkiem		Kg	767
2.3 Nacisk na przednią oś bez ładunku		Kg	42
2.3 Nacisk na tylną oś bez ładunku		Kg	21

## Opony/rama

3.1 Koła sterujące			POLY.I./ NYLON
3.2 Rozmiar kół napędowych - Średnica		mm	200
3.2 Rozmiar kół napędowych - Szerokość		mm	55
3.3 Rozmiar rolek - Średnica		mm	82
3.3 Rozmiar rolek - Szerokość		mm	60
3.5 rozmiar kół: koła tylne - ilość (X-napędzane)		nr	4
3.5 Tylna oś balansująca			No
3.6 Ślad, przód	b10	mm	155
3.7 Ślad, tył	b11	mm	375

## Wymiary

4.4 Wysokość podnoszenia	h3	mm	115
4.9 Wysokość dyszla w pozycji pracy maks	h14	mm	1160
4.15 Wysokość, opuszczony	h13	mm	85
4.19 Całkowita długość	l1	mm	1550
4.20 Długość do podstawy wideł	l2	mm	400
4.21 Całkowita szerokość	b1	mm	525
4.22 Wymiary wideł - grubość	s	mm	55
4.22 Wymiary wideł - Szerokość	e	mm	150
4.22 Wymiary wideł - Długość	l	mm	1150
4.25 Odległość pomiędzy widłami	b5	mm	525
4.32 Prześwit od ziemi, środek rozstawu osi	m2	mm	30
4.34 Szerokość korytarza roboczego	Ast	mm	1835
4.35 Promień skrętu	Wa	mm	1367

## Osiągi

5.2 Prędkość podnoszenia z ładunkiem	strokes		13
5.2 Prędkość podnoszenia bez ładunku	strokes		13

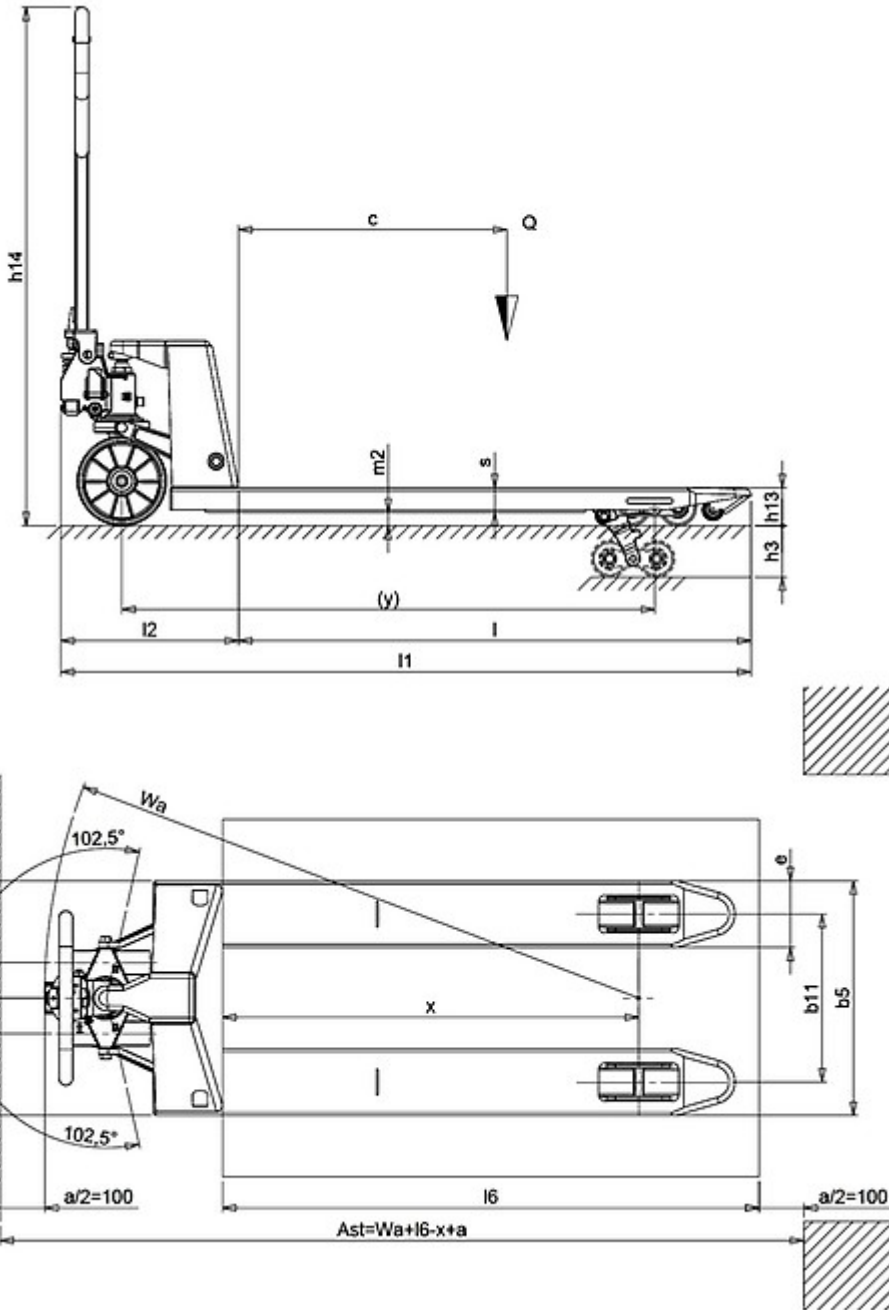

The information is aligned with the Data file at the time of download. Printed on 03/07/2018 (ID 564)

©2018 | PR INDUSTRIAL s.r.l. | All rights reserved | Image shown may not reflect actual package. Specifications subject to change without notice

